

N

Noto

WELCOME TO NOTO

Design for a positive future

APPROACH

Understanding humans to design life enriching experiences

Noto's strategic approach is deeply rooted in the understanding of human psychology. We believe sustainability, both for your business success and for our future, needs to start with mindfulness. That beautiful experiences must reflect meaning. And that pioneers have to challenge the existing.



VALUE

Design is our universal language. Whether in a digital or in a physical landscape. Collaborating with us can grow your portfolio, create new business opportunities or build your entire brand identity.

EXPERTISE

Strategic thinking and design doing in various projects across industries.

Expect to be challenged and surprised when working with us. If you let us do, we will lead you into new and expanding markets for long-term business success. We will ensure that our joint activities will have a positive impact on the future. And the experiences we create will be beautiful and evoke emotion.

More about our expertise [[here](#)]



STRATEGY

Together we position your product portfolio ahead of the competition with a unique design language that matches your brand and make your business more sustainable.

#Design Guideline

#Range Development

#Circular Economy

#Contextual Research



INNOVATION

With a deep understanding what people need, we challenge the benchmarks in your industry. Innovation is change and change is our opportunity.

#Ethnographic_Research

#Trend_Radar

#Ideation_&_Co-Creation

#Testing





Suisse Int'l Mono

Artifact Industries

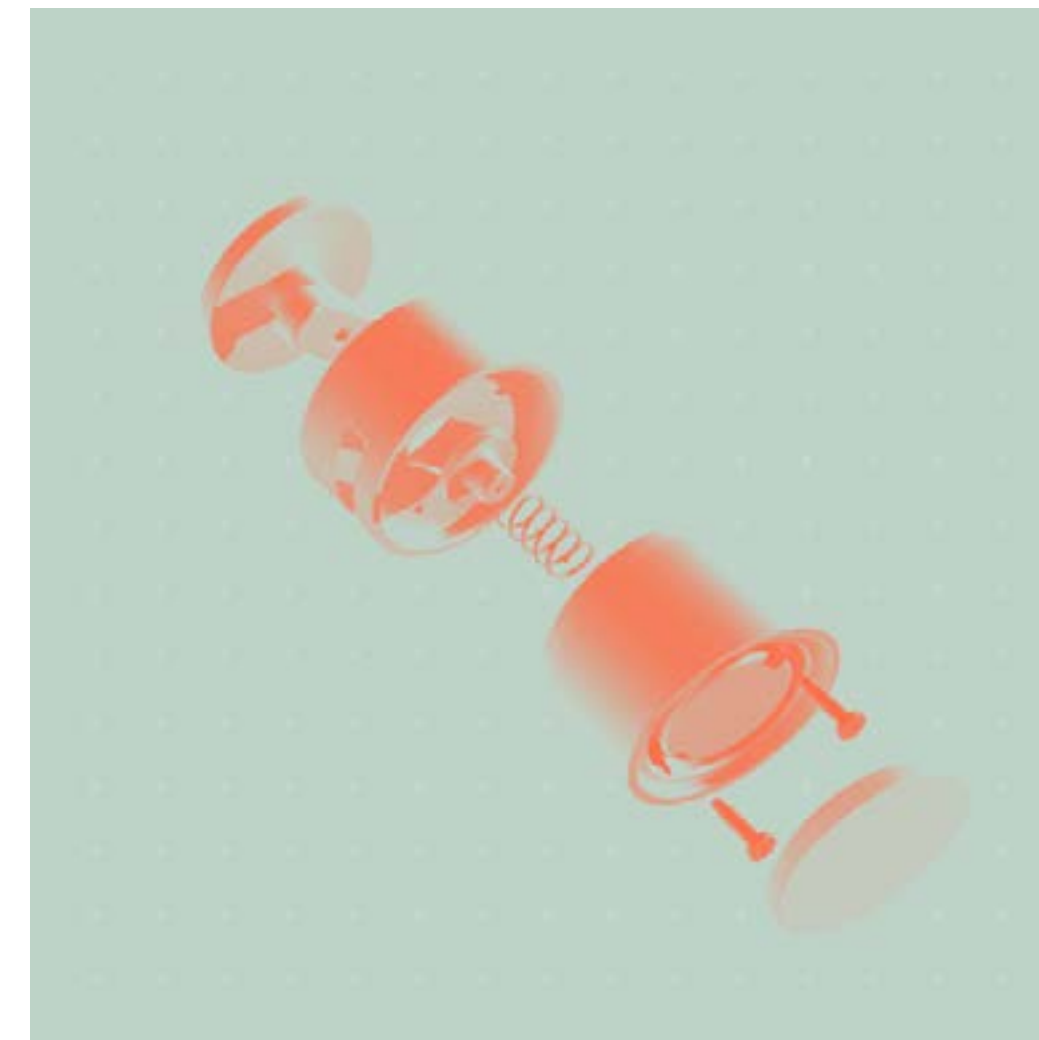
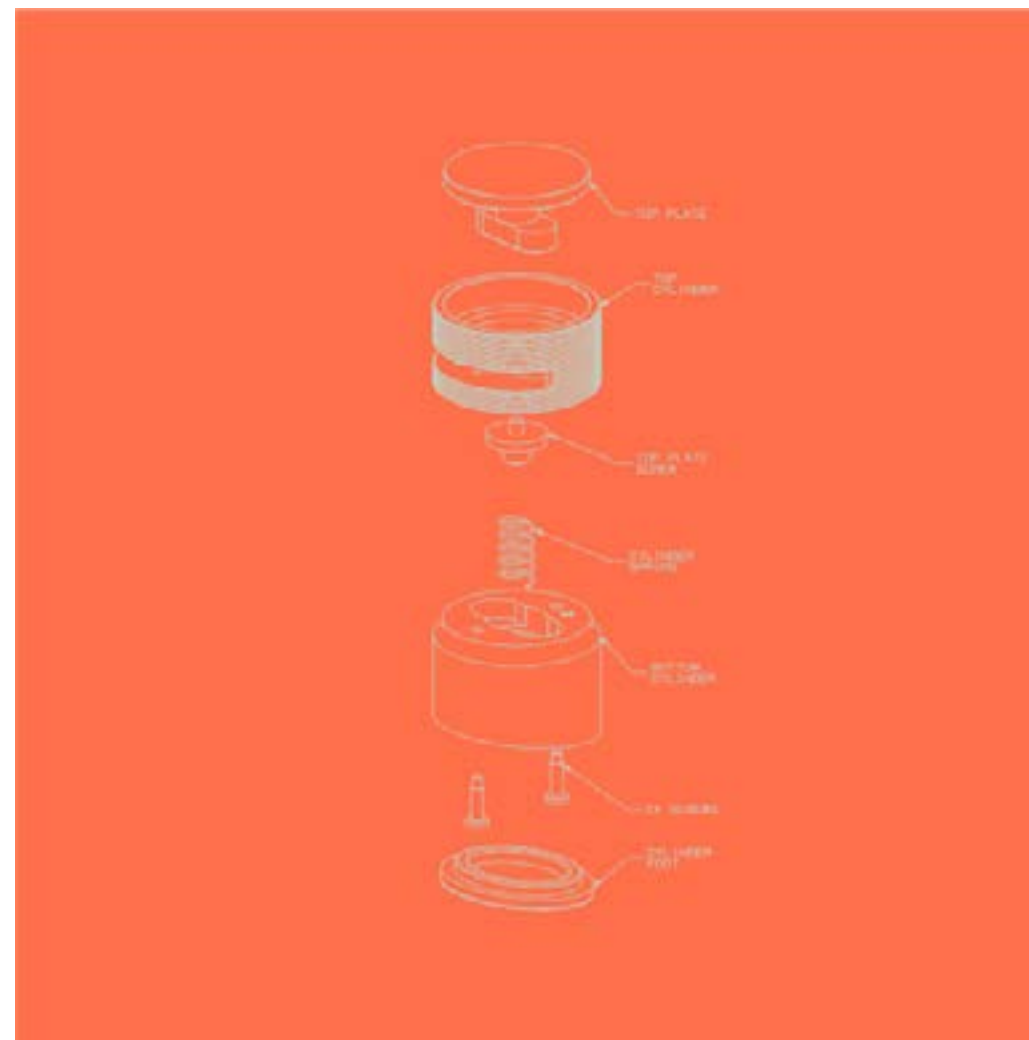

BRAND

To accelerate your idea we construct your brand's entire architecture with a distinct corporate identity that captures the attention of your audience.

- #Corporate_Design
- #Storytelling
- #Packaging
- #Marketing_Assets_&_CGI

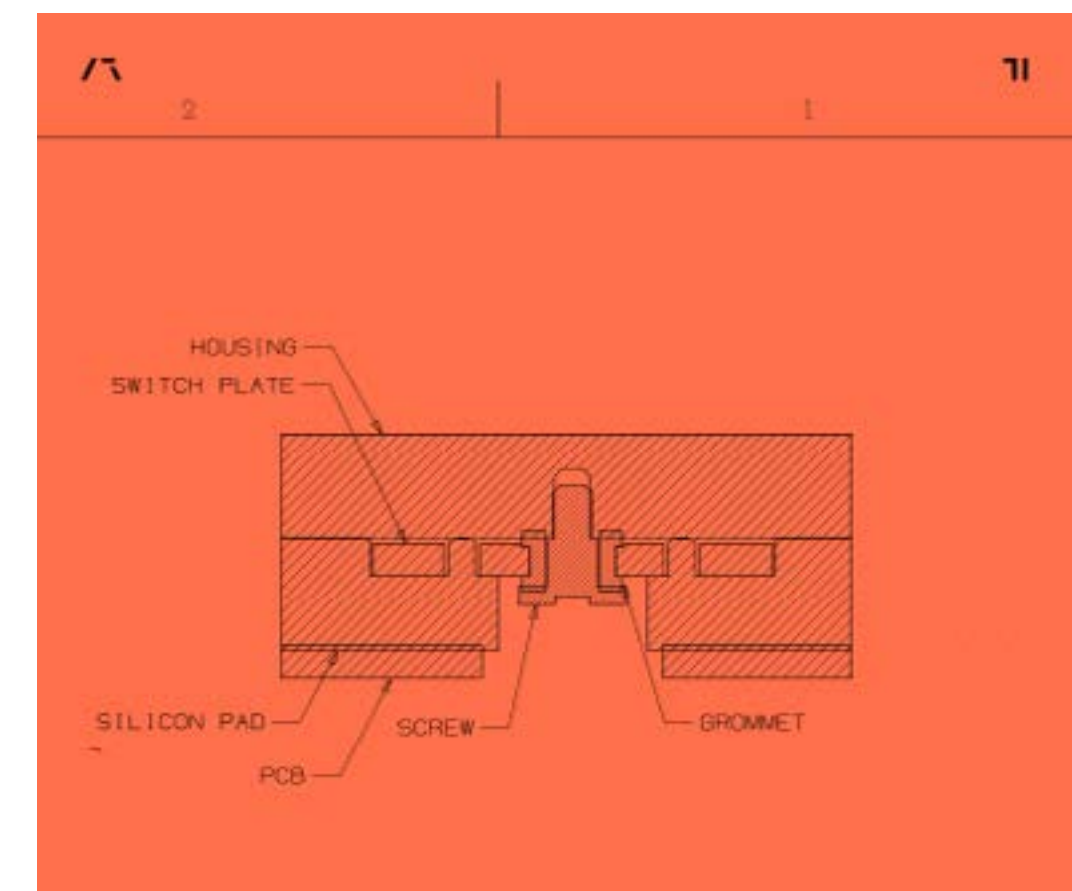
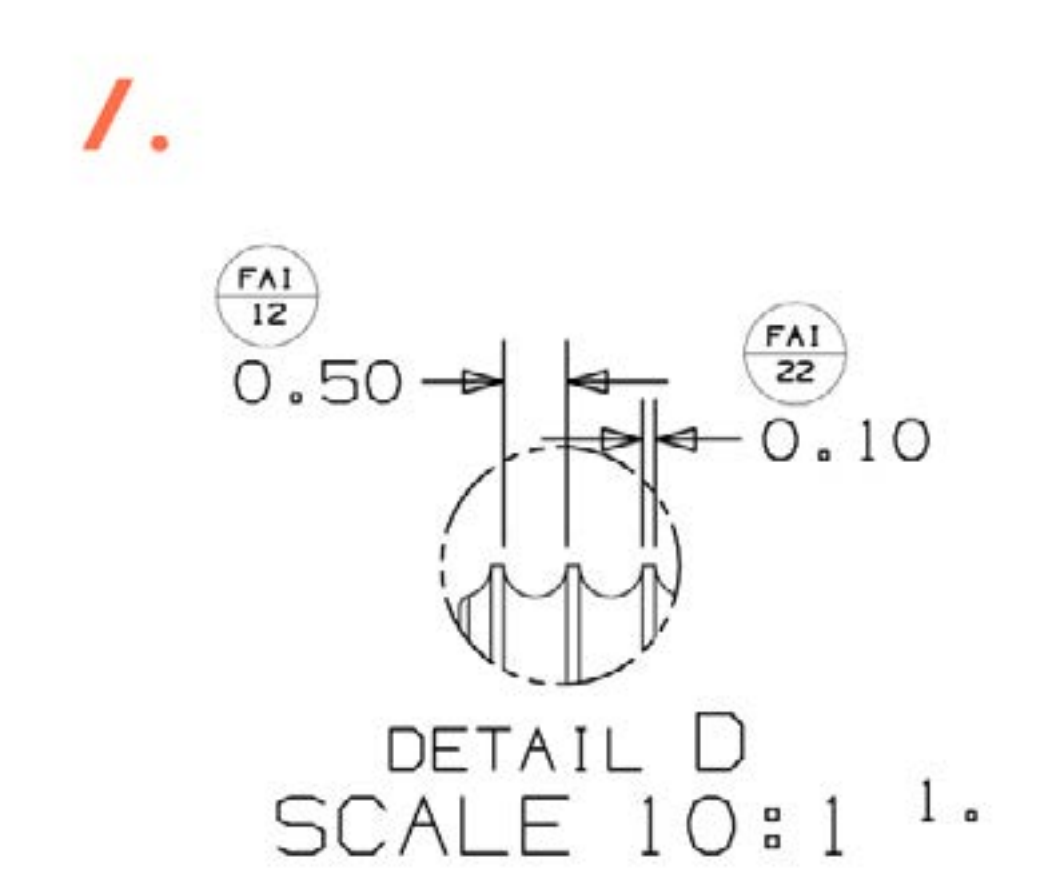

PRODUCT

Our progressive design ideas will awaken the desire in your products and surprise you. With our collaborative attitude we will bring magic ideas to life – together.

#Concepts_beyond_expectations

#Color_Material_Finish

#Design_for_Manufacturing

#Prototyping

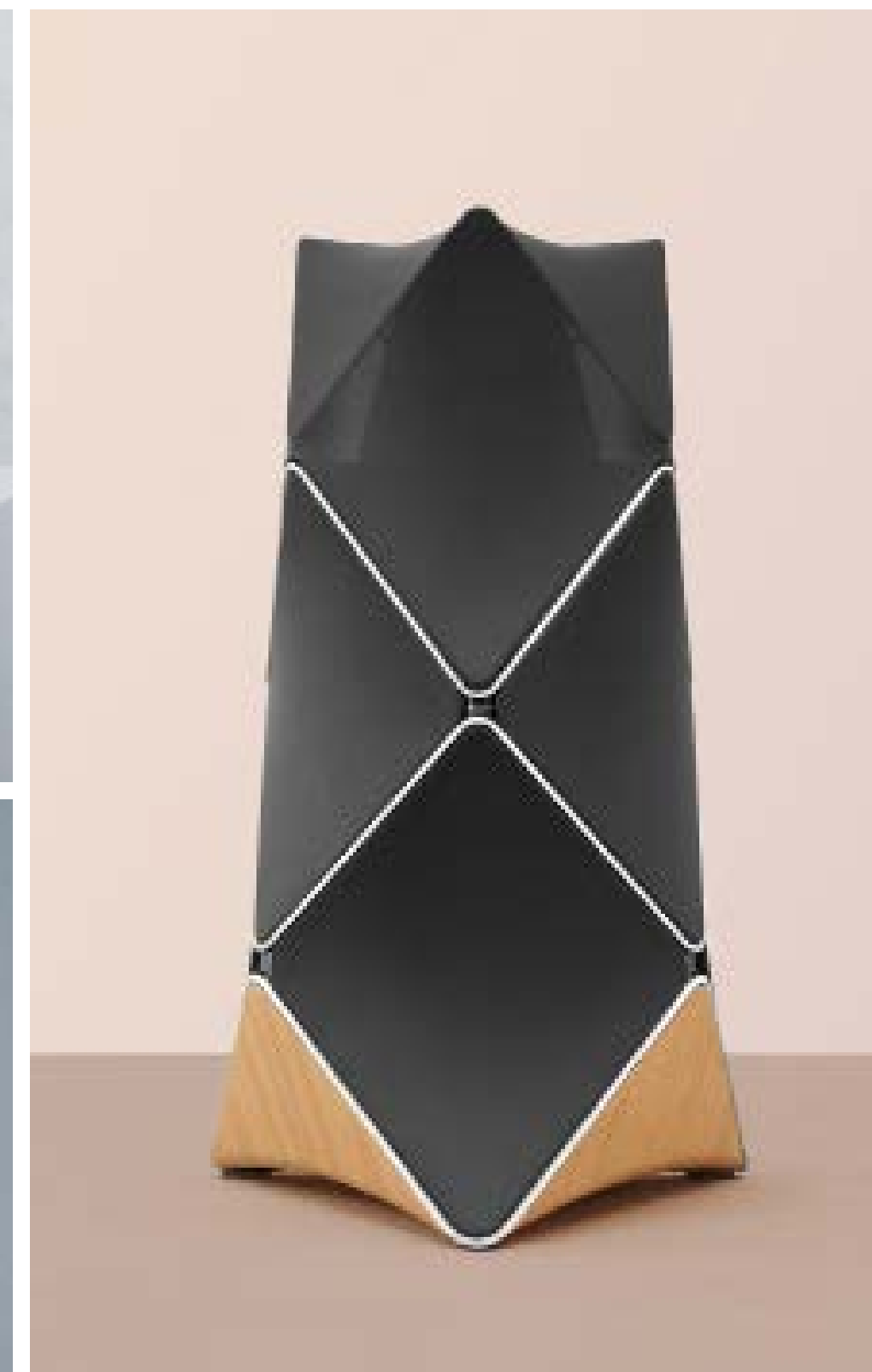

INTERACTION

We design seamless digital (and physical) experiences for customers to enjoy. Creating solid UI and UX interactions on device or as an environmental extension.

#UX/UI_Design
#Customer_Journey
#Prototyping
#Validation



CREDIBILITY

Selected and awarded

We are trusted partner for industry leading global companies as well as for SMU and accelerating, promising start-ups. Our work has been recognized and awarded with the most prestigious design awards, such as the Design Award of the Federal Republic of Germany in Gold and red dot best of the best and many more.

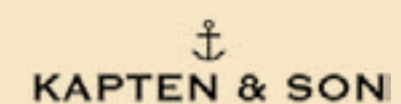

CONTACT

Looking forward to talking to you

ANDRÉ POULHEIM

Co-Founder & Managing Partner

poulheim@noto.design

STUDIO COLOGNE

Noto GmbH

Kalscheurener Str. 19

D-50354 Huerth

+49 2233 4600100

hello@noto.design

WWW.NOTO.DESIGN



N

Noto

A POSITIVE FUTURE NEEDS TO BE DESIGNED

Ready to team up?